

# SHEET METAL NIBBLER CUTTER

Thank you for your purchase. Please read this instruction carefully before operation.



## Warning

- ❖ Please do not cut the sheet thicker than stipulated below.
- ❖ Do not use the tool beyond the operating scope herein.
- ❖ Do not use the tool under unusual circumstances to avoid any possible accident.
- ❖ Do not change any inner structure or reassemble the tool without the advice of the manufacturer.

## CHARACTERISTIC

- Unique convenience and durability.
- Excellent cutting speed by 2 meter per minute with 3000PRM.
- Best cutting result without any burrs at the cutting edges.
- 360-degree changeable direction at operation.
- To be fitted with any electric drill or power drill with 3000RPM.
- Different cutting shapes available.

## NOTE

- ✓ Tighten any screw before using the tool.
- ✓ Never start operation before the motor runs.
- ✓ Keep a vertical angle of the cutting bit to the sheet.
- ✓ Release the bit in operation while the motor is still running.
- ✓ Please use special bit-cooling oil at operation.

## CAPACITY

For the best performance, please follow the following stipulated thickness of the sheet plate

Material Type	Iron Plate	Stainless Steel Plate	Copper or Aluminum Plate	Plastic or Plywood
Thickness (Max)	1.8mm	1.2mm	2.0mm	2.0mm

## OPERATION

1. Fasten the plate to be cut on to an operating platform.
2. Fit the tool with an electric drill or any power drill by fastening the drill chuck.

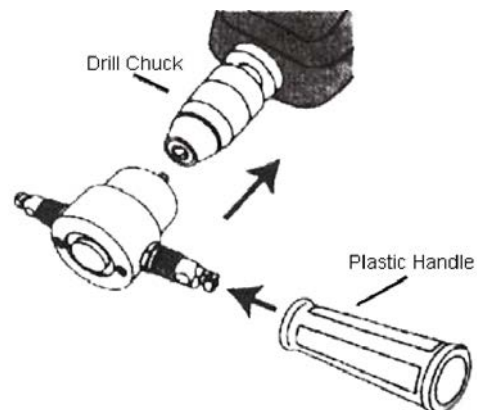
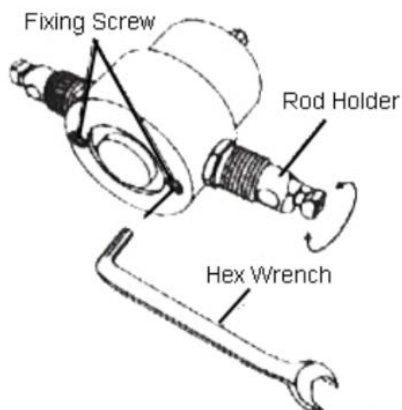

3. Operate the tool when the motor runs.
4. Release the cutting bit when the motor keeps running.
5. Use special bit-cooling oil at operation.
6. See the picture below for more information when the tool is fitted to a drill.

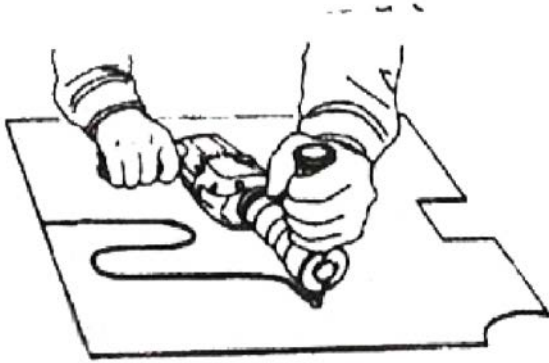

## REPLACEMENT

### Rod replacement:

1. Loosen the screw on the rod holder.
2. Loosen the set screw and pull out the rod.
3. Fix the center hole in the rod into the right position of the sliding block and then tighten the set screw.
4. Tighten the screw on the rod holder.
5. Install the cover and lock ring.

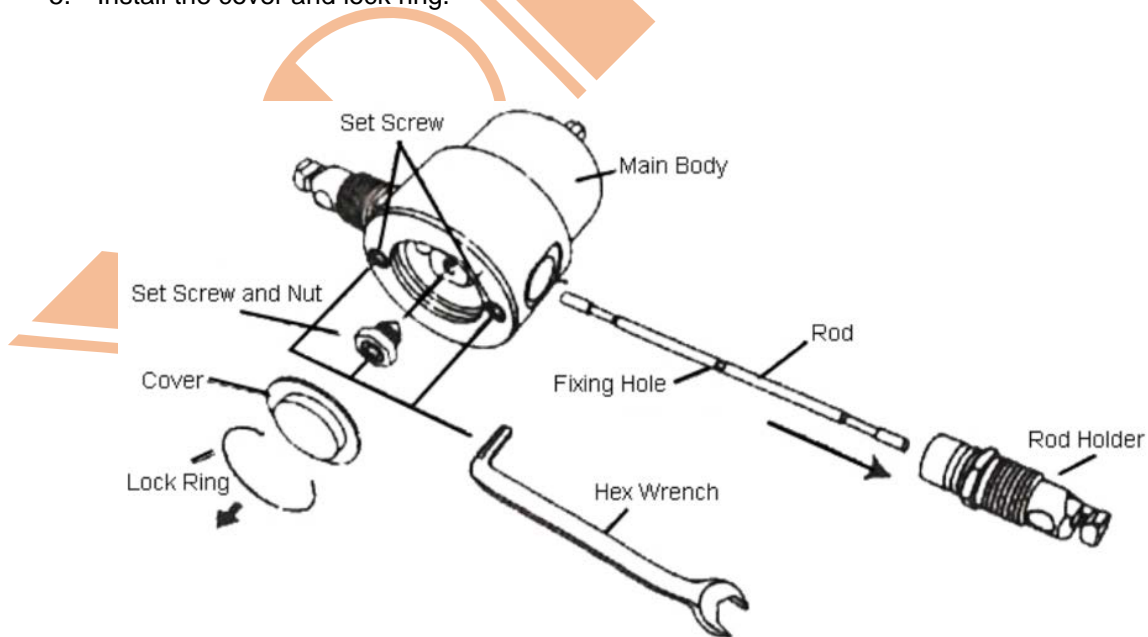

**Rod holder replacement:**

Loosen the screw slowly with the hex wrench to release the rod holder for replacement.

*As shown on picture.*

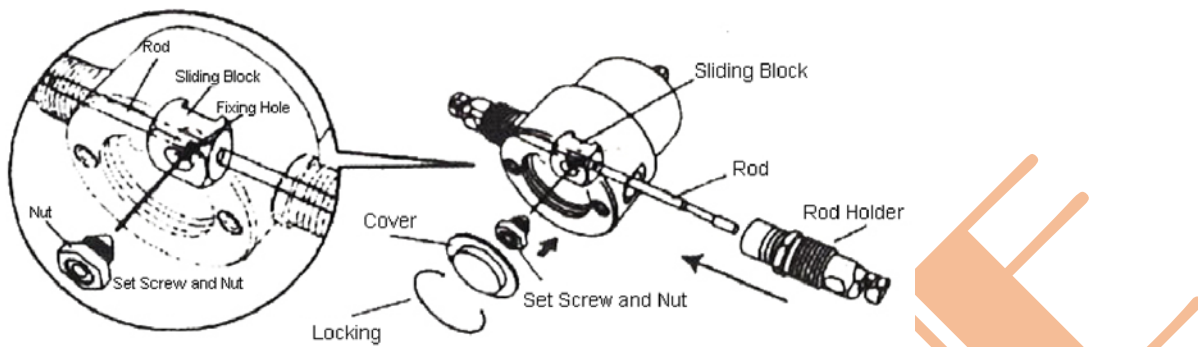
**ITEMS INCLUDED:**

1 x Sheet Metal Nibbler Cutter Set

1 x Hex Wrench Tool

Note: this user manual subject to change without notification